



JSB-D12-55 (12V55Ah)

JSB-D1255 is AGM Deep cycle battery with 10 years floating Design life, specially designed for frequent cyclic discharge usage. By using strong grid and specific paste plate, it makes battery have 30% more cyclic life time than standby series. It is applicable for solar energy system, golf cart, electric wheelchair, etc..



Specification

Cells Per Unit	6
Voltage Per Unit	12
Capacity	55Ah@10hr-rate to 1.75V per cell @25°C
Weight	Approx. 18.0 Kg
Max. Discharge Current	550 A (5 sec)
Internal Resistance	Approx. 6 mΩ
Operating Temperature Range	Discharge: -20°C~60°C Charge: 0°C~50°C Storage: -20°C~60°C
Normal Operating Temperature Range	25°C±5°C
Float charging Voltage	13.6 to 13.8 VDC/unit Average at 25°C
Recommended Maximum Charging Current Limit	16.5A
Equalization and Cycle Service	14.6 to 14.8 VDC/unit Average at 25°C
Self Discharge	JALpower batteries can be stored for more than 6 months at 25°C. Self-discharge ratio less than 3% per month at 25°C. Please charge batteries before using.
Terminal	Terminal F11/F15
Container Material	A.B.S. (UL94-HB) , Flammability resistance of UL94-V1 can be available upon request.



MH28539



G4M20206-0910-E-16



ISO9001:2000 Certificate

Dimensions

Unit: mm Dimension: 229(L)×138(W)×235(H)

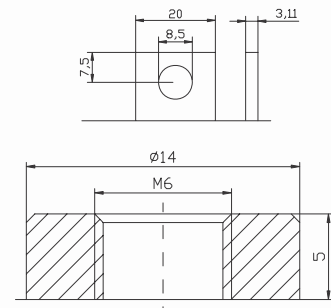
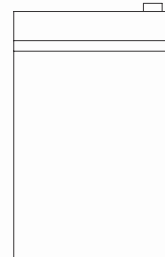
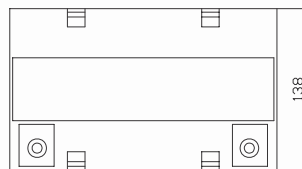
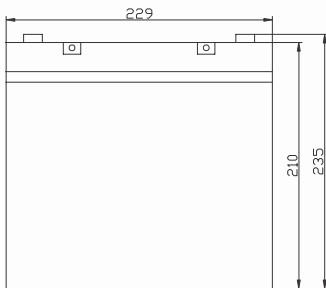

Constant Current Discharge Characteristics: A (25°C)

F.V/Time	5MIN	10MIN	15MIN	30MIN	1HR	2HR	3HR	4HR	5HR	8HR	10HR	20HR
9.60V	189.6	135.8	98.84	60.72	34.32	19.46	13.78	11.40	8.976	6.559	5.546	2.933
10.0V	184.5	129.3	96.81	59.72	34.16	19.31	13.73	11.35	8.923	6.505	5.492	2.879
10.2V	173.9	124.7	95.29	59.19	33.84	19.16	13.62	11.30	8.870	6.452	5.439	2.826
10.5V	156.1	115.1	90.73	57.71	33.53	19.01	13.57	11.19	8.765	6.399	5.386	2.773
10.8V	140.9	104.9	83.64	55.18	32.74	18.66	13.20	10.93	8.606	6.292	5.332	2.719
11.1V	122.7	93.8	75.02	51.69	31.10	18.36	12.62	10.40	8.237	6.025	5.172	2.559

Constant Power Discharge Characteristics: W (25°C)

F.V/Time	5MIN	10MIN	15MIN	30MIN	1HR	2HR	3HR	4HR	5HR	8HR	10HR	20HR
9.60V	1975	1445	1064	685.2	392.5	230.2	159.0	131.8	103.9	76.11	62.36	32.94
10.0V	1935	1380	1041	676.7	390.6	229.3	158.7	131.5	103.3	75.79	61.72	32.62
10.2V	1827	1334	1027	668.8	387.8	227.2	157.8	130.8	103.0	75.15	61.40	32.30
10.5V	1645	1232	979.6	653.6	384.0	225.1	156.8	129.9	102.0	74.51	60.76	31.98
10.8V	1480	1119	900.1	623.8	374.5	221.8	153.0	126.4	100.4	72.91	60.12	31.66
11.1V	1277	993.8	803.7	584.5	354.8	211.6	145.4	120.4	95.36	70.35	58.20	30.38

All mentioned values are average values.

Life characteristics of cyclic use

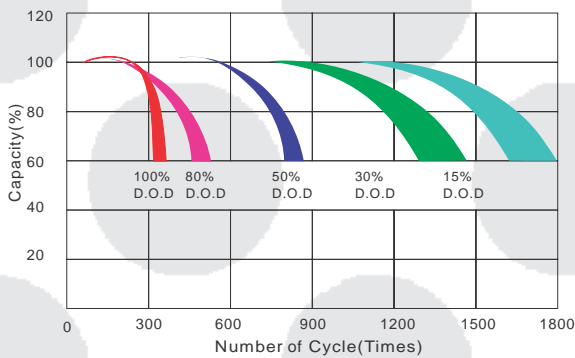

Storage characteristic

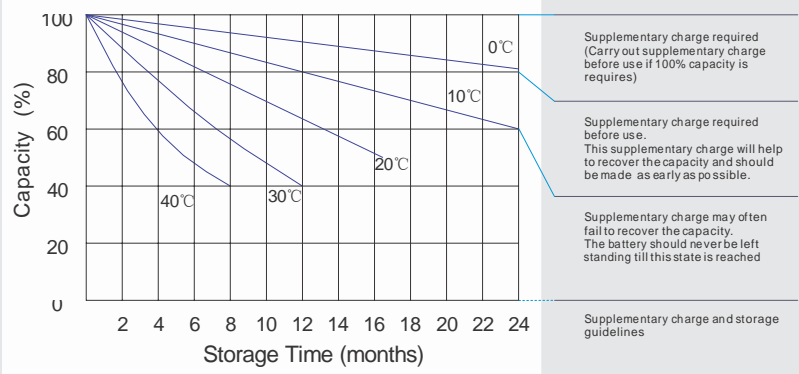

Charge characteristic Curve for standby use

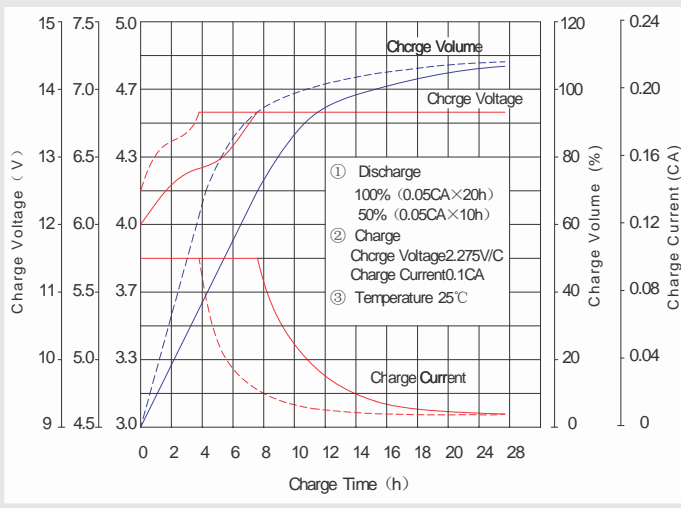

Discharge characteristic Curve

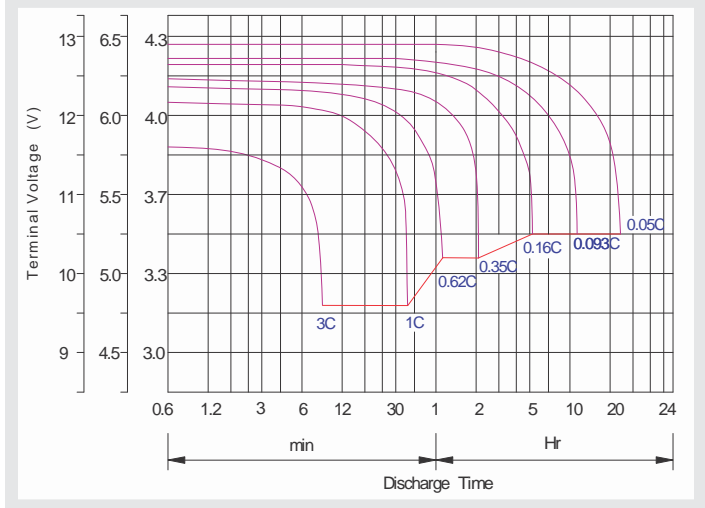

Capacity Factors With Different Temperature

Battery Type		-20°C	-10°C	0°C	5°C	10°C	20°C	25°C	30°C	40°C	45°C
GEL Battery	6V&12V	50%	70%	83%	85%	90%	98%	100%	102%	104%	105%
	2V	60%	75%	85%	88%	92%	99%	100%	103%	105%	106%
AGM Battery	6V&12V	46%	66%	76%	83%	90%	98%	100%	103%	107%	109%
	2V	55%	70%	80%	85%	92%	99%	100%	104%	108%	110%

Discharge Current VS. Discharge Voltage

Final Discharge Voltage V/cell	1.75V	1.70V	1.60V
Discharge Current (A)	(A) ≤ 0.2C	0.2C < (A) < 1.0C	(A) ≥ 1.0C

Maintenance & Cautions

Cycle service

- ※ Avoid battery over discharge, especially battery series connection use.
- ※ Charged with recommend voltage, ensure battery can be full recharged.
- In general, recharge capacity should be 1.1-1.15 times discharge capacity.
- ※ Effect of temperature on cycle charge voltage: -4mV/°C/Cell.
- ※ There are a number of factors that will affect the length of cyclic service.
- The most significant are depth of discharge, ambient temperature, discharge rate, and the manner in which the battery is recharged.
- Generally speaking, the most important factors is depth of discharge.

Charge the batteries at least once every six months, if they are stored at 25°C.

Charging Method:

Constant Voltage	-0.2Cx2h+2.4~2.45V/Cellx24h, Max. Current 0.3CA
Constant Current	-0.2Cx2h+0.1CAx12h
Fast	-0.2Cx2h+0.3CAx4.0h